

OnSpec xSil 146 IDE Flash Media Reader Controller Chip

Product Data Sheet

The xSil 146 provides a low cost and low component solution to connect IDE host to various memory card formats such as CF, MMC/SD, MS/MS PRO, SM/xD, NAND and HDD. It contains the following features:

- 128-pin 16mm x 16mm LQFP package
- Built-in oscillator
- Serial port
- Two General Purpose Timers
- Watchdog Timer
- 16 bit RISC Processor
- Internal RAM for firmware enhancements and data transfer
- Internal ROM contains BIOS and Application code.
- Serial EEPROM for firmware enhancements for Flash media
- Optimum hardware controlled transfer for speed and scalability
- Supports up to IDE PIO mode 4 and UDMA mode 5 data transfer on Host side.
- Supports up to IDE PIO mode 6 and UDMA mode 5 data transfer on Device side.
- Supports ATA protocol

Device Support

- Memory Stick™ / Memory Stick PRO™ with different form factors
- Secure Digital™/MultiMediaCard™ with different form factors
- CompactFlash™ Type I and II
- Microdrive™
- SmartMedia™
- xD™
- NAND
- HDD

Host Support

IDE Interface with ATA protocol.

Data Transfer rate for Flash media

Taken in Windows XP SP2 with HDBench

Media Tested	Read Speed (in KB/s)	Write Speed (in KB/s)	Random Read Speed (in KB/s)	Random Write Speed (in KB/s)
CF 4GB Lexar 300x	43097	43096	40943	9795
CF 2GB SanDisk Extreme IV	40442	33257	37440	8358
CF 1GB SanDisk Extreme III	20670	20289	19441	4200
MMC PLUS 512MB Transcend	11202	10112	11069	2079
miniSD 2GB Transcend	13794	10976	13158	1080
SD 2GB SanDisk Extreme III	26202	25296	22135	4938
SD 2GB SanDisk Extreme III	23914	19616	20157	3393
MS Classic 256MB(128MBx2) Sony	1417	816	482	244
MS HS 64MB SanDisk MG	2202	970	626	296
MS PRO DUO 512MB Sony MG	4602	4288	4550	816
MSPRO Extreme III – 1GB	18002	17382	16027	4457
SM 64MB Samsung	9175	1242	2200	494
xD H 2GB Fujifilm	6443	645	1088	249

Patents:

This product is covered by one or more of the following patents:

US Pat. 5784584, 5809336, 5841424, 6438638, 6598148, 6832281, 6859361, 6859369

Taiwan Pat. I 222564

China Pat. CN 018152163

S. Korea Pat. KR 476817

Other Foreign & US Patents Pending

Disclaimer:

Information in this document is provided in connection with OnSpec Electronic products. No license, express or implied, by estoppel or otherwise, to any intellectual property rights is granted by this document. Except as provided in OnSpec Electronic's Terms and Conditions of Sale for such products, OnSpec Electronic assumes no liability whatsoever, and OnSpec Electronic disclaims any express or implied warranty, relating to sale and/or use of OnSpec Electronic products including liability or warranties relating to fitness for a particular purpose, merchantability, or infringement or any patent, copyright or other intellectual property right.

OnSpec Electronic products are not intended for use in medical, life saving, or life sustaining applications.

Trademarks:

OnSpecLink is a registered trademark of OnSpec Electronic, Inc.

All other trademarks are the properties of their respective owners.

Mechanical Dimensions

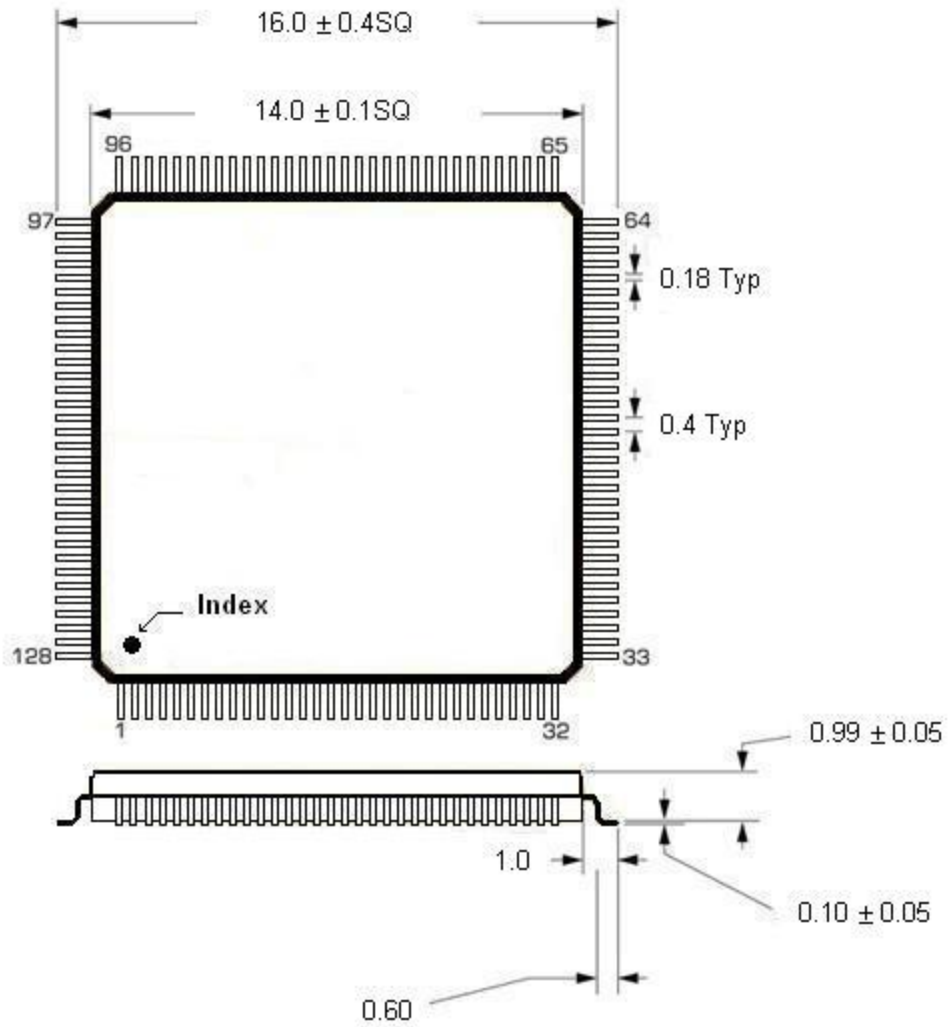

Note: All Dimensions are in mm

Typical Application

The xSil 146 Controller is used in PC based and embedded based application to connect Flash media cards to IDE Interface. Any Standalone device such as DVD Recorder needs to connect Flash media cards to IDE Host; xSil 146 controller is the ideal solution. Figure below shows the block diagram of 146 Controller Application. This controller can be used in the following applications.

IDE Kiosk – IDE to Multi Slot Flash Media Card Reader.

IDE to CF - IDE to CF Card Reader.

IDE to SD - IDE to SD Card Reader.

eSATA Kiosk – SATA to Multi Slot Flash Media Card Reader – xSil 146 can be connected to any SATA to PATA bridge.

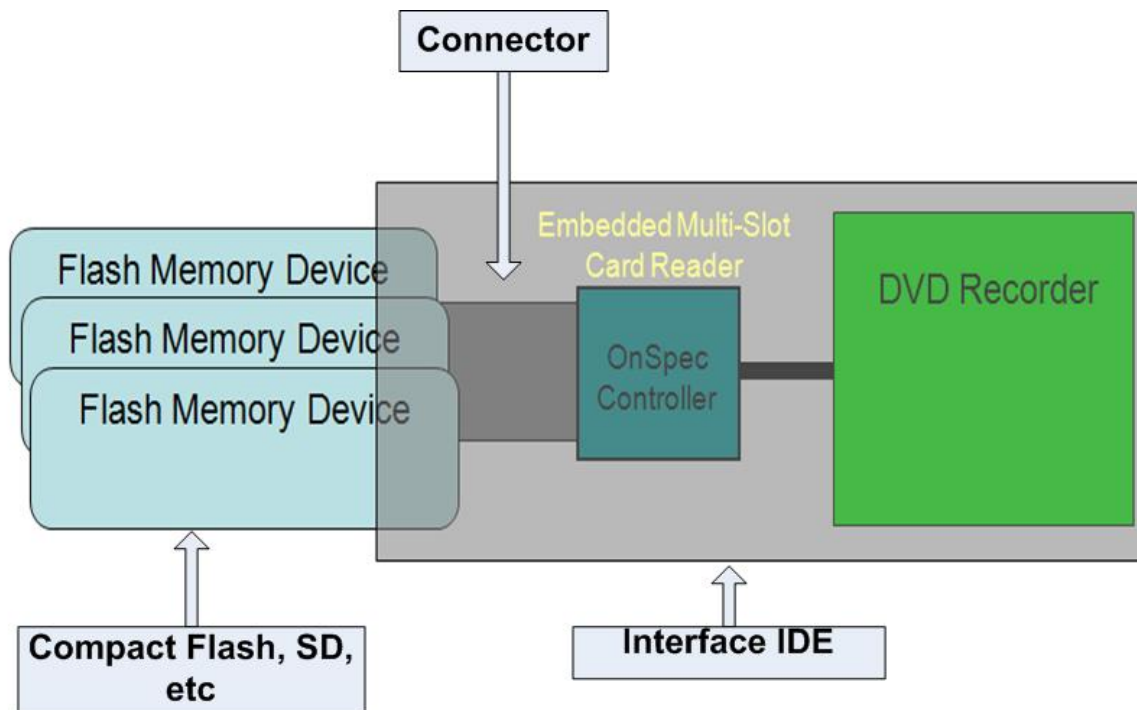

xSil 146 Application