

OnSpec

xSil 261B Hi-Speed USB to IDE Hard Drives or CompactFlash V3.0 Drives With AES Encryption Security Product Data Sheet

The xSil 261B is designed to connect an IDE with embedded AES encryption to USB has the following features:

- 48-pin 7mm x 7mm LQFP package
- Single chip with integrated USB 2.0 PHY
- Embedded AES encryption
- Serial EEPROM port
- UDMA Modes 0..4 supported
- MDMA Modes 0..2 supported
- PIO Modes 0..6 supported
- IDE interface
- Serial port
- Two General Purpose Timers
- Watchdog Timer
- 16 bit Processor
- Internal RAM for supporting enhancements
- ROM with BIOS and Application code.
- Programmable Read and Write widths
- PD-DRM support to report unique serial number
- Optimum hardware controlled transfer for speed and scalability

IDE Hard Disk Drives / Removable IDE Hard disk drives

- Supports UDMA Modes 0..4, MDMA Modes 0..2, PIO Modes 0..4
- Supports Hard drives of up to 2048GB (2TeraBytes)

Mechanical Dimensions (Preliminary)

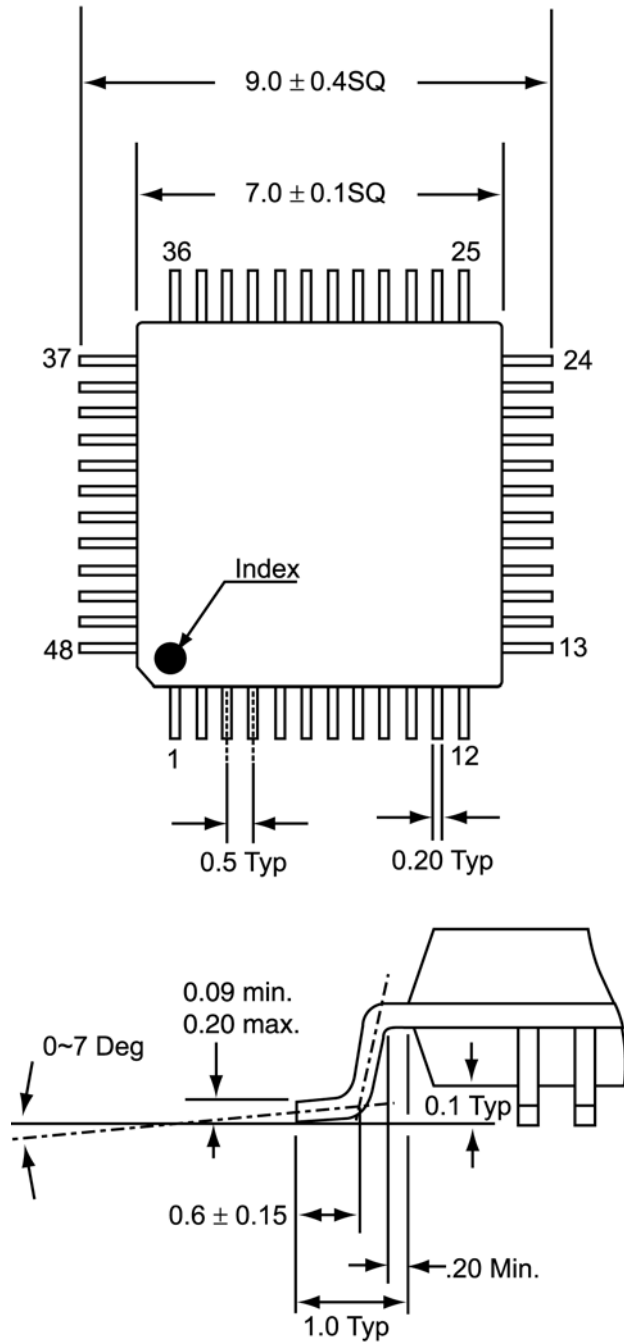

All dimensions are in mm.

OnSpec

Patents:

This product is covered by one or more of the following patents:

US Pat. 5784584, 5809336, 5841424, 6438638, 6598148, 6832281, 6859361, 6859369, 7095618

Taiwan Pat. I 222564

China Pat. CN 018152163

S. Korea Pat. KR 476817

Other Foreign & US Patents Pending

Disclaimer:

Information in this document is provided in connection with OnSpec Electronic products. No license, express or implied, by estoppels or otherwise, to any intellectual property rights is granted by this document. Except as provided in OnSpec Electronic's Terms and Conditions of Sale for such products, OnSpec Electronic assumes no liability whatsoever, and OnSpec Electronic disclaims any express or implied warranty, relating to sale and/or use of OnSpec Electronic products including liability or warranties relating to fitness for a particular purpose, merchantability, or infringement or any patent, copyright or other intellectual property right.

OnSpec Electronic products are not intended for use in medical, life saving, or life sustaining applications.

Trademarks:

OnSpecLink is a registered trademark of OnSpec Electronic, Inc.

All trademarks are the properties of their respective owners